



寿力螺杆式空气压缩机·工频及变频 Lubricated Rotary Screw Air Compressors Constant Speed and Variable Speed Drives

WS1800-7500 / WS1800-7500VSD

WS4500-7500PS / WS4500-7500PSVSD

寿力工频空压机 Constant Speed Drive Performance

型号 Model	马达 Motor HP	额定排气量 Capacity at Full Load Pressure - m³/min				重量 Weight - kg
		7.0bar	8.0bar	10.0bar	12.0bar	
1800	25	—	2.9	2.6	2.2	610
2200	30	—	3.55	3.1	2.8	680
3000	40	—	4.75	4.1	3.4	820
3700	50	6.8	6.3	5.8	5.1	1020
4500	60	8.5	7.8	6.9	5.65	1250
4500PS	60	8.6	7.7	—	—	1270
5500	75	10.5	9.5	8.6	7.6	1300
5500PS	75	10.9	9.9	—	—	1320
7500	100	13.5	12.5	10.5	—	1350
7500P	100	13.9	12.9	11.5	10.5	1500
7500PS	100	13.9	12.9	11.5	10.5	1520

寿力变频空压机 Variable Speed Drive Performance

型号 Model	马达 Motor HP	额定排气量 Capacity at Full Load Pressure - m³/min				重量 Weight - kg
		7.0bar	8.0bar	10.0bar	12.0bar	
1800VSD	25	—	1.0-3.0	0.86-2.6	0.73-2.2	675
2200VSD	30	—	1.2-3.6	1.03-3.1	0.93-2.8	745
3000VSD	40	—	1.58-4.75	1.42-4.25	1.23-3.7	885
3700VSD	50	2.27-6.8	2.1-6.3	1.93-5.8	1.7-5.1	1100
4500VSD	60	1.93-8.5	1.91-7.93	—	—	1320
5500VSD	75	2.52-10.6	2.52-9.85	2.12-8.6	2.09-7.73	1400
7500PVSD	100	3.36-14.1	3.3-12.9	2.65-11.8	2.59-10.5	1600
7500PSVSD	100	1.68-14.1	1.65-12.9	1.33-11.8	1.3-10.5	1620
7500VSD	100	3.21-13.5	3.26-12.55	2.76-10.5	—	1450

设备尺寸 Dimensions

型号 Model	长 Length - mm	宽 Width - mm	高 Height - mm
1800、2200系列	1350	800	1350
3000、3700系列	1574	875	1562
4500、5500、7500系列	2300	1180	1750



18-75 kW / 25-100 HP
Rotary Screw Air Compressors



美国寿力

中山市顺力机电设备有限公司

TEL: 0760-88639018 FAX: 0760-88639013

[Http://www.zs88613178.com](http://www.zs88613178.com)

24 小时紧急服务专线: 139 2817 0110

地址: 中山市石岐区安山大街西 12 巷 6 号

SULLAIR. 美国寿力
Always air. Always there

空压机领域的又一革命

The Next Revolution in Compressor Design

自1965年以来，寿力公司一直引领螺杆空压机技术领域的发展方向。我们凭藉40多年的经验，对这一领域进行了新一轮的革新一向市场提供紧凑、耐用、安静、易维修的WS1800到WS7500系列空压机。事实上，它的设计在各个方面制定了新的标准：

- ④ 尺寸紧凑
- ④ 低噪音
- ④ 易维修
- ④ 节能
- ④ 低运行成本
- ④ 空气品质高

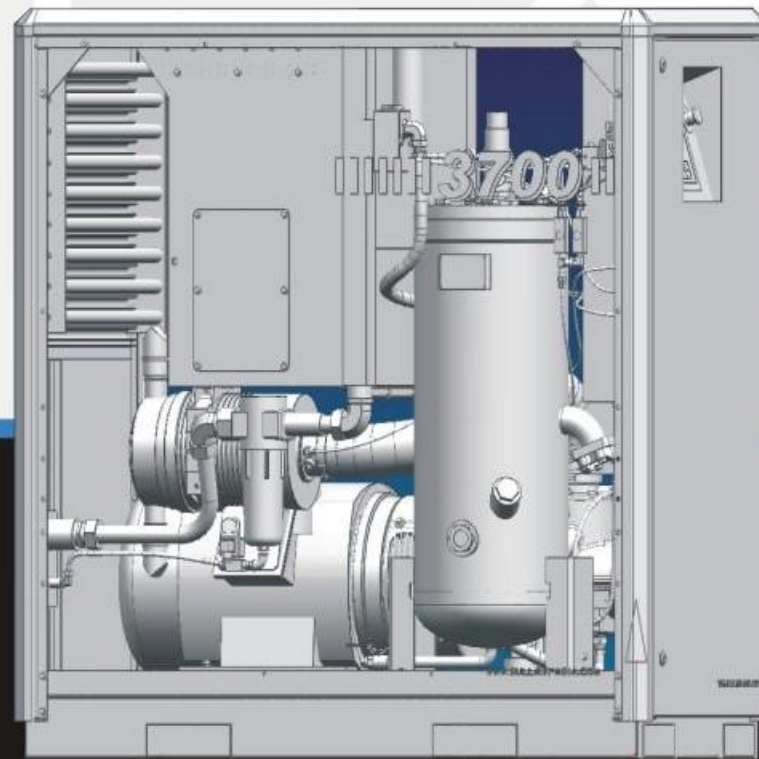

As an industry leader since 1965, Sullair pioneered rotary screw technology. We applied our 40 years of compressor know-how to the development of this series. The result is truly revolutionary. Sullair reliability in the compact, robust, maintenance-friendly and quiet compressor package available on the market. It sets new standards in virtually every category:

- ④ compact size
- ④ cost of operation
- ④ energy efficiency
- ④ serviceability
- ④ low sound levels
- ④ air quality

寿力专业压缩空气系统的保证

Sullair Professional Compressed Air Quality Guarantee

为满足不同客户的不同用气需求，寿力公司为广大用户提供高质量的空气压缩系统。寿力系统包括寿力空压机，寿力干燥机和寿力过滤器。寿力系统设备能够为您提供压力恒定的供气设备。寿力保证：我们的设备像金子一样……

Sullair provides compressed air systems that meet your plant air or process requirements. The Sullair System matches a Sullair compressor, a Sullair dryer and Sullair filters. You can be assured that the quality of air from the Sullair System you specify will remain consistent for the life of the equipment. Sullair guarantees it... and that's as good as gold.

空气品质保证

寿力压缩空气系统提供的压缩空气品质可以达到、超过ISO标准（ISO 8573.1，油气等级1和粉尘等级2）。系统包括寿力空压机，寿力干燥机和寿力PF,PH和PC过滤器。

The Sullair Critical Air Quality Guarantee

The compressed air from this Sullair System exceeds the ISO standard (ISO 8573.1, Class 1 for oil vapor and Class 2 for Particulate). The System includes a Sullair compressor, Sullair dryer, and Sullair PF, PH, and PC filters.

关注环境

基于利用自然资源创造和提供能源的理念，寿力公司致力于提供空气压缩机使能源利用最为有效。

WS系列空压机的其他有利于环境的特征如下：

- ④ 全封闭保护盘预防维护时空压机润滑油等溅出
- ④ 无芯润滑油过滤器是非金属材质，废旧过滤器可焚烧或压碎，省却了复杂的废物处理过程
- ④ 寿力 Sullube™ 润滑油是可生物降解的
- ④ 使用低噪音风扇设计，健康和舒适、舒适
- ④ 寿力减震器遍布主机、马达及储气罐等部位，而进气、排风均有绝缘部件保护

A Concern for the Environment

Mindful of our natural resources that are used to create and supply electrical energy, Sullair is focused on conservation and committed to providing air compressors that will use this energy most efficiently.

Other environmental features of the WS Series compressors include:

- ④ Fully-sealed protection pan that will contain compressor fluid should any spill while servicing
- ④ Coreless fluid filter of non-metallic design that can be either incinerated or crushed, virtually eliminating disposal concerns and expense
- ④ Sullair's environmentally compatible fluid, Sullube™, is biodegradable
- ④ Health and safety issues are addressed by utilizing a low noise fan design, for worker comfort
- ④ Additionally, Sullair mounts air-end, motor, and receiver on rubber isolators and insulates intake and exhaust louvers

与众不同的标配优势 Features and Benefits That Set Sullair Apart



标准型中英文微电脑控制器

标准型中英文微电脑控制器为标准配置，安装角度充分考虑了人机工程学。紧急停机按钮不用担心被误操作！

- ① 机组的信息可通过RS485接口以Modbus通讯协议上传。
- ② 可以通过控制器面板上的键盘来控制压缩机，设定控制参数。系统图上的指示灯反映各显示参数所处的位置及状态。
- ③ 具有主机电流、温度、压力、运行时间、工作状态、电源电压偏差（参考值）、环境温度等参数实时显示及报警功能。
- ④ 四十条报警记录与不断刷新的历史运行信息记录，方便维护和分析。
- ⑤ 具有主机电流保护功能，自带电源电压检测及过压、欠压保护功能。

Sullair Microprocessor Controller

Sullair Microprocessor Controller is standard outfit. Installation angle is considerable, no need to worry about any misapplication.

- ① Rs485 ports, with standard Mod-bus.
- ② The panel can control compressor, set up the compressor data, The indicators show the operating conditions of the compressor.
- ③ Environment temperature, pressure dew point temperature, motor current, temperature, pressure, operation time, operation situation & power pressure windage can be displayed and warned all at times.
- ④ 40 warning records and updated history records make maintenance and analysis easy.
- ⑤ Electrical current protection function for main motor with power supply, voltage inspection and over/low protection.

品质卓越的标准配置

- ① 高性价比长寿命的轴承、转子及消耗件
- ② 低于2个PPM的空气含油量
- ③ 优质的马达冷却性能保证马达使用寿命
- ④ 联机控制
- ⑤ NEMA4标准
- ⑥ WS微电脑控制标准
- ⑦ 环境、健康及安全的设计特性

Standard Features

- ① Low life cycle costs including long life bearings, rotors, and consumable parts
- ② Less than 2 ppm fluid carryover
- ③ Excellent motor cooling design characteristics for longer motor life
- ④ Sequencing standard
- ⑤ NEMA 4 standard
- ⑥ WS microprocessor standard
- ⑦ Environmental, health, and safety design features

寿力通过以下几点为您节省能源:

- ① 带组合进气阀的久经考验的主机
- ② 高效风扇
- ③ 低压降油气分离系统预防能源损失
- ④ 优化的空气过滤系统(10倍于其它过滤系统效能)可以延长油气分离器和油滤芯的寿命，减少润滑油的损耗
- ⑤ 为了降低处理废弃润滑油的成本，寿力公司还提供环保的、可降解的Sullube™8000小时润滑油。

Contributing to the energy savings are:

- ① Sullair's proven air-end with the low restriction inlet valve
- ② High efficiency fan
- ③ Low pressure drop air-fluid separation system to prevent energy loss
- ④ Improved air filtration (10 times better filtration than other filters) translates into: Extended separator life Improved fluid filter life Less lubricant contamination
- ⑤ To reduce fluid disposal costs, we offer our biodegradable Sullube™ 8000-hour fluid.

比以前任何时候都便利 Sullair Compressor are Easiest to Maintain

寿力WS1800-7500空压机简化日常维修工作。不少于6个革命性的特点使得空压机维护变得更干净，更安全，运行更节能。

The Sullair WS1800-7500 simplifies routine maintenance. No less than 6 features revolutionize the compressor's serviceability and make for a cleaner, safer work environment and cost-effective compressor.



宽敞的维护保养空间
Unimpeded Access to
Inside the Compressor



电磁排水阀
Electric Solenoid
Drain



可快速更换温控阀
Quick Thermostat
Change
To change the
thermostat, simply
thread the old
thermostat out,
and the new one in.



吹扫、清洁冷却器方便简单
Quick Access to Cooler



可以直接检查冷却液位而不用打开空压机。
Easy Fluid Check
You can check the fluid level directly from the front panel without opening the machine.



该机型设置了一个完全密封的环境保护盘，确保在维护时产生的液体泄露被完全收集。
A fully-sealed environmental protection pan assures that fluid is contained should any drips occur while servicing.

无芯润滑油过滤器是非金属材质，废的过滤器可焚烧或压碎，省却了复杂的废物处理过程。

A new coreless fluid filter features a non-metallic design which can either be incinerated or crushed, virtually eliminating disposal issues.

寿力WS1800-7500

The Sullair WS1800-7500

当今世界上最安静的空压机之一

寿力公司WS1800-7500系列空压机集合了很多设计理念以降低机器噪音，达到理想状态。

- ④ 机头、马达及TANK都安装了橡胶减振垫
- ④ 安装了进气口和出气口栅格
- ④ 低噪音离心式风扇

One of the quietest compressor available today

The Sullair WS1800-7500 incorporate many design features that reduce the noise of the machine, making it ideal for point-of-use installations.

- ④ Air-end, motor, and receiver tank mounted on rubber isolators
- ④ Insulated intake and exhaust louvers
- ④ Low-noise centrifugal fan

低运行成本，长运行寿命

新的WS1800-7500系列产品在整个设备寿命周期内持续节能。高效空滤器过滤效果是同行业常用纤维素过滤器的10倍。空气质量的提高能够延长油气分离芯、油过滤器的寿命，减少润滑液的消耗。

Lower overall costs for the life of your machine

The new WS1800-7500 designs deliver cost savings over the life of the product. The highly efficient Optimal Air Filter provides filtration that is 10 times better than the standard cellulose media air filters commonly used in the industry. Improved air filtration translates into extended separator life & improved fluid filter life. Further more, it makes lubricant contamination less.

寿力WS1800-7500系列节能、环保机型

能源成本占空压机长期运行总成本的77%，寿力WS1800-7500系列新机型以显著降低能源成本的方式为客户提供节能方案：

- ④ 久经考验的机头（带组合进气阀）
- ④ 高效冷却风扇
- ④ 低压降油气分离系统

More reasons why we are known as the green machines

Considering that energy costs represent 77% of the total cost of owning compressors, these savings significantly reduce energy costs. The Sullair WS1800-7500 reinforce Sullair's reputation for providing energy-saving solutions that significantly reduce operating and energy costs using:

- ④ Sullair's proven air-end with the integrated inlet valve
- ④ High efficiency centrifugal fan
- ④ Low pressure drop air-fluid separation system to reduce energy consumption

贯通的空气气流循环冷却主电机和风扇电机，延长电机寿命。齿轮设计成高螺旋角度，提高接触比，减少齿轮应力。增加轴承寿命。寿力新WS系列产品具备的上佳的适用性意味着您可以在维护保养上花费更少的时间。

Full ambient air flow over both the compressor motor and the fan motor, extends motor life. Our gears are designed with high helix angles to improve the contact ratio for reduced gear stresses and increased bearing life. And the best-in-class serviceability means you spend less time on maintenance, allowing your facility to run at peak efficiency and uptime.

寿力变容调节系统（WS4500-WS7500选配）能够：

- ④ 准确地匹配所压缩的气量和耗气量
- ④ 在部分负载时，可节能高达17%
- ④ 排气压力稳定

Sullair variable capacity control can :

- ④ Match compressor output with demand exactly
- ④ Uses up to 17% less power
- ④ Offers stable output

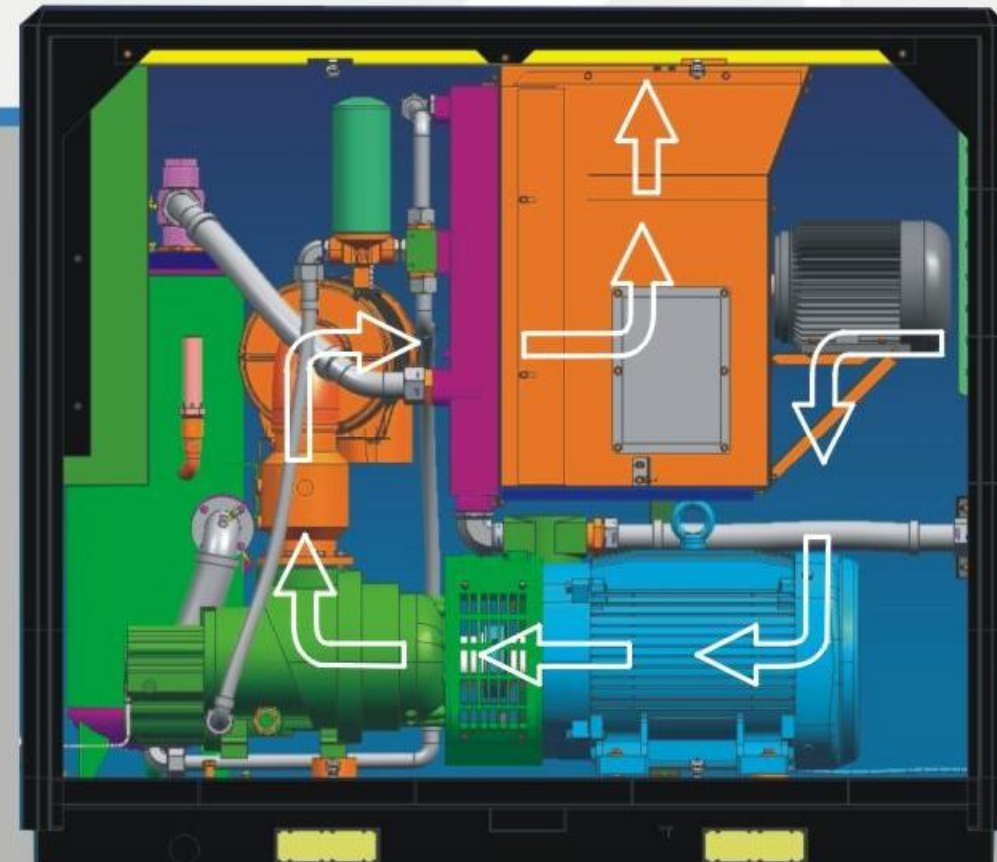

真正的变频空压机

Completely True Variable Speed Air Compressor

在空压机寿命周期内均能节约能源

当排气压力波动范围大时，选用变频空压机节能效果最显著。这个系列的空压机与其他空压机相比节能效果尤为显著。

Total life cycle costs

Energy savings are maximized when the compressor doesn't have to overcome high pressure drop conditions. This Series provides significant savings over standard compressors.

高效变频电机

- 采用特殊的电磁设计，有效抑制了高次谐波对电机的危害，并提高了电机低频输出转矩。
- 采用专用变频电机漆包线，加强了对地绝缘和匝间绝缘强度，特别是绝缘耐冲击电压能力大大增强。
- 有效避免了低频共振现象。
- 采用特殊冷却方式，保证了电机在低频运行也具有充足的自冷却能力。



寿力变频空压机性能卓越

Sullair VSD Compressors with Smart Technology

变频器

- 更换功率元件部分时，无需设置任何参数
- 控制部分可完全独立于功率部分
- 高防护等级，3相电流检测
- 功率模块为金属外罩
- 集成EMC滤波器的最新铁芯技术的集成交流电抗器
- 宽范围电压输入范围为323V - 550V
- 可插拔选项模块系统
- 支持总线通讯的应用软件包
- 外部24V供电时，可进行参数设置和总线控制



VSD Controller

- Power parts can be replaced without loss of parameter settings
- Control module fully separated from power module
- Advanced protections, 3 phase current measurements
- Power module is all metal enclosure
- Integrated AC chokes. New Ferrite Core Technology with EMC filters
- Wide input voltage range is from 323V - 550V
- Uses pluggable option module system (5 modules)
- "All in One+" Application Package with fieldbus support
- External 24V supply possible for parameter setting and Fieldbus Control

High efficiency variable frequency motor

- Adopts special electromagnetic design, effectively inhibits the hazard of high harmonic wave in the motor and improving the motor low frequency output torque.
- Adopts special enameled wire for variable frequency motors, enhancing grounding insulation and turn-to-turn insulation strength. In particular, the impact voltage resistance of the insulation is greatly enhanced.
- Effectively avoids low frequency resonance.
- Adopts special cooling design, ensuring sufficient self-cooling ability even at low frequency.

软启动是标准配置

电机从20Hz开始软启动，不需要使用Y-三角或其他启动方式。对电机、压缩机、电网的冲击大大减少。不再频繁的加载和卸载，供气压力稳定，提高了产品质量。采用高效变频控制器，变频器安装在控制柜内。

Soft starting is the standard configuration

The motor experiences soft starting from 20Hz and doesn't require Y-delta or other soft starting equipment. The impact of starting on motor, compressor and power grid is greatly reduced. No frequent loading and unloading, stable air supply pressure, and improved product quality. High-efficiency variable speed drive controller, which is installed in the electrical cabinet.



5年螺杆总成保固

在正常环境条件下，按寿力相关指导操作，寿力公司对螺杆总成承诺：

- 五年内没有质量问题
- 五年内相关技术参数不变

5-YEAR WARRANTY ON SULLAIR AIR END

In normal ambient condition, when used according to Sullair recommendations, we guarantee the Air ends:

- No quality problems for 5 years
- No change in performance for 5 years



寿力WS1800-7500变频空压机

The Sullair WS1800-7500 VSD

变频压缩机为您节约能源

节能是变频压缩机的最大优点-尤其是当用户用气量波动范围较大时。其灵活性和可靠性，使得变频压缩机的节能优势更为明显。变频调节是适应系统气量需求变化的最有效的控制方式。

Variable speed drive compressor saves energy for you

Energy saving is the largest advantage of a variable speed compressor, especially when the user's demand fluctuations range are large. Its flexibility and reliability makes the energy conservation capability of variable speed compressor more obvious. Variable frequency regulation is the most effective control mode for adapting to the air volume changes.

变频器也可以实现软启动，当达到设定时间(一般6秒后)会自动切换到满负荷状态。当用气量小于额定排气量时，变频机组将通过降低变频电机的频率，相应降低进气量；当客户停止用气时，变频电机的频率降至最低，停止进气，此时，机组处于低转速空载状态，在较低的背压下运行。

Variable speed drive controller controls the soft starting of the motor. When reaching the set time (normally after 6sec), it will automatically switch to the full load mode. When air consumption volume is smaller than the rated discharge volume, the variable frequency unit will reduce the air intake volume accordingly by reducing the frequency to the variable frequency motor; when the user stops air consumption, the frequency of the variable frequency motor is reduced to the minimum, stopping air intake. At this time, the machine will run at low back pressure, in the idle mod.

在空压机整个使用寿命中，由于购买和使用空压机的费用中有77%左右是用于电费，因此，节电的问题就十分重要。Considering that energy costs represent 77% of the total cost of owning compressors, these savings significantly reduce total life cycle costs.

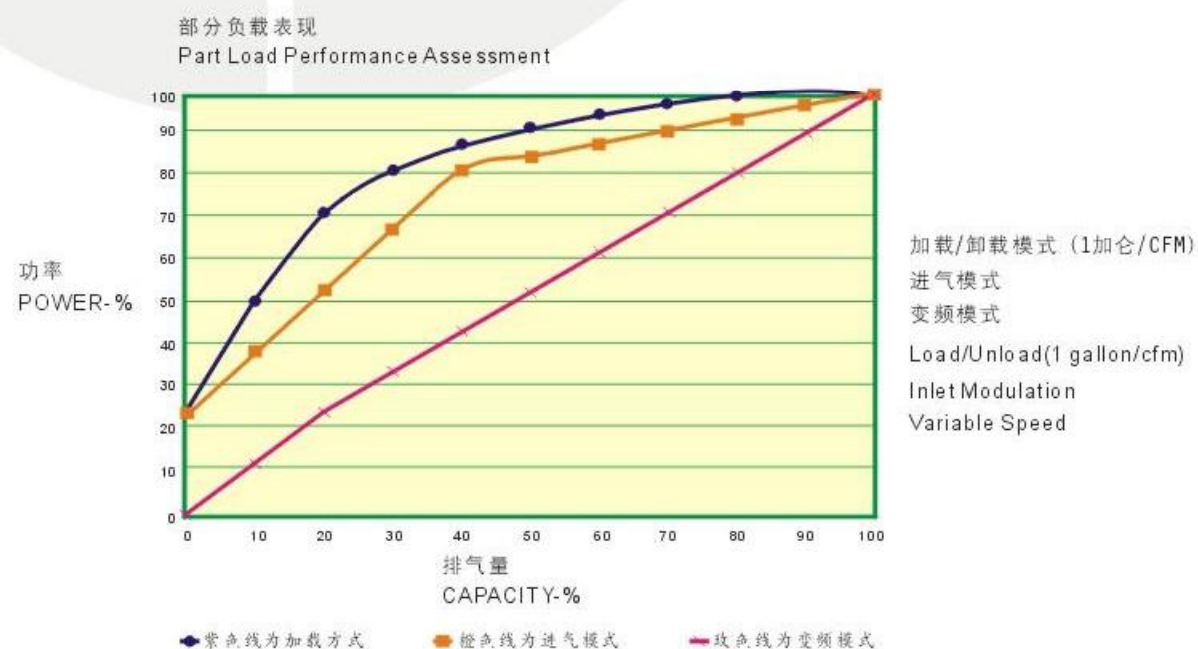

比以往更节能

Easier than Ever to save energy

变频压缩机可使您不需关注气量的变化高峰

寿力空压机能够在全频段内保持功率因数最高，可有效防止企业因功率因数过低引起的各种问题。

Variable speed drive avoids potential peak demand charges

Sullair compressors provide the highest power factor over the entire frequency range, often avoiding utility company penalties.

无启动和停机次数的控制

不必要控制冷/热启动的次数。无启动和停机次数的限制，节省电费。

Unlimited starts and stops

No need to control the number of hot or cold starts
Unlimited starts and stops save electrical cost.

空压机可安全自动调节

寿力变频空压机既可以自动调节排气量，也可以自动调节排气压力。这种灵活性使得您可能不必增加其他空压机就能使您的空气系统扩容。

Total compressor flexibility automatically with safety built in

Sullair's Variable Speed Drive provides the flexibility to vary both capacity and pressure. This flexibility makes it possible to "grow" your air system without adding another compressor.

稳定的系统压力

保证生产过程的连贯性并减少废品率。

可使管网的压力变化范围精确地保持在0.1bar左右。

另外可以：

- ⊙ 减少空气系统泄露
- ⊙ 减小空气系统存储要求
- ⊙ 减少能耗，提高利润

Stable system pressure

Improves the consistency of your process and product to reduce product rejects.

It stabilizes the pressure range to around 0.1 bar in piping network. In addition to:

- ⊙ Fewer air system leaks
- ⊙ Reduced system storage requirements
- ⊙ Increased energy savings for increased profits



普通的系统压力
Conventional
System Pressure



寿力变频系统压力
Sullair VSD System
Pressure